

SWAN model HV-203 Two stage 2 cyl. air cooled

Rev. No. CS0308-HV203

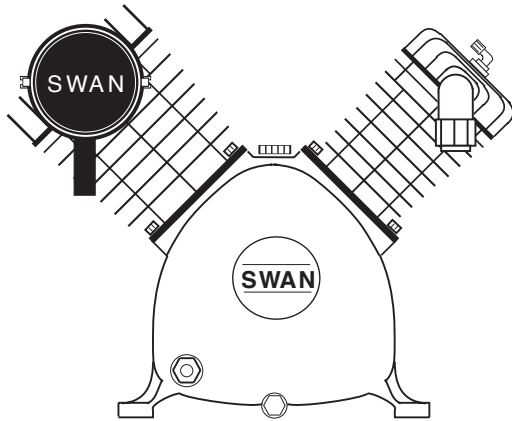

HV-203 PERFORMANCE

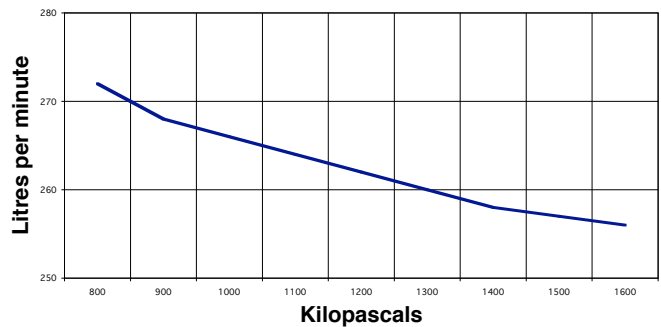

Main Construction Material	Cast Iron				
Bore	mm	L82 H42			
Stroke	mm	70	Piston Displacement	L/min	357
Minimum Speed	rpm	550	Free Air Delivery @ 1378 kPa	L/min	258
Normal Speed	rpm	960	Shaft Input:		
Maximum Speed	rpm	1200	@ 1034 kPa	kW	1.96
Minimum Working Pressure	kPa	345	@ 1205 kPa	kW	2.06
Maximum Working Pressure	kPa	1725	@ 1378 kPa	kW	2.17
Minimum Ambient Temperature	Celsius	0°	@ 1550 kPa	kW	2.24
Maximum Ambient Temperature	Celsius	45°	Temperature of Air Discharge:		
Air Connection Comp. Fitting	mm	20	@ 1034 kPa	Celsius	117°
Air Cleaners	Dry Paper Type		@ 1205 kPa	Celsius	129°
Bore Lubrication	Splash Feed		@ 1378 kPa	Celsius	138°
Oil Capacity of Crankcase	Litres	0.910	@ 1550 kPa	Celsius	146°
Type of Drive	V-belt	2A	Maximum Lubricant Consumed		
Approximate Net Weight	kgs	49	in 100 hours Operation	millilitre	78.95
Rotation Looking at Flywheel	Anti-clockwise		Noise Level at 1 metre	dB(A)	82

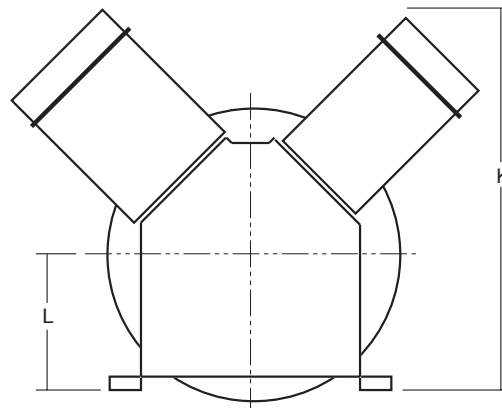
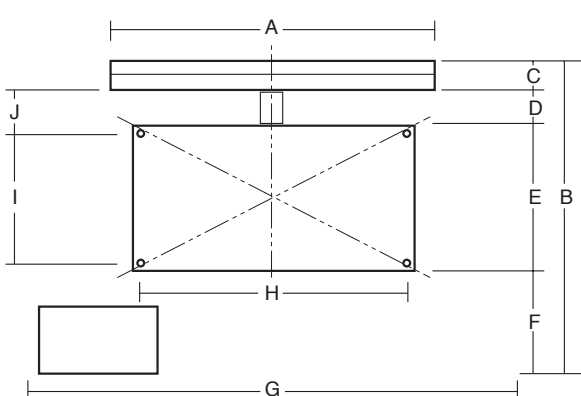

A	290 mm
B	400 mm
C	50 mm
D	20 mm
E	185 mm
F	95 mm
G	550 mm
H	258 mm
I	135 mm
J	45 mm
K	410 mm
L	125 mm

Forbes (Aust) Pty Ltd reserves the right to change the specifications of any of its products without prior notice