

### SWAN model SD-203 Single stage OIL FREE 2 cyl. air cooled

Rev.  
No. CS0412-SD203

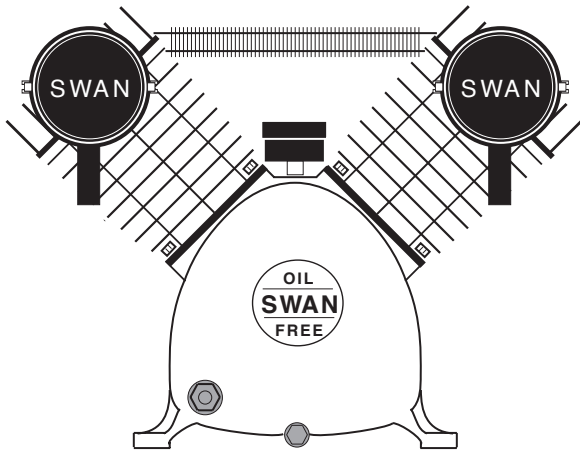

### SD-203 PERFORMANCE

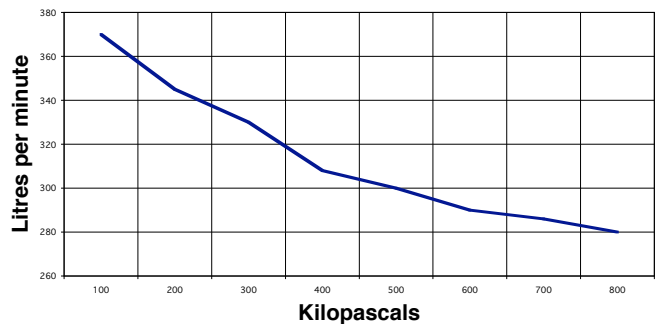

Main Construction Material	Cast Iron / Alloy	<i>The following are at normal speed with an ambient temperature of 31.1°C &amp; inlet air of 101 kPa g pressure.</i>			
Bore	mm	83	Piston Displacement	L/min	406
Stroke	mm	55	Free Air Delivery @ 689 kPa	L/min	286
Minimum Speed	rpm	200	Shaft Input:		
<b>Normal Speed</b>	<b>rpm</b>	<b>700</b>	@ 415 kPa	kW	1.69
Maximum Speed	rpm	700	@ 551 kPa	kW	1.77
Minimum Working Pressure	kPa	275	@ 689 kPa	kW	1.91
Maximum Working Pressure	kPa	850	@ 850 kPa	kW	1.98
Minimum Ambient Temperature	Celsius	0°	Temperature of Air Discharge:		
Maximum Ambient Temperature	Celsius	45°	@ 415 kPa	Celsius	103°
Air Connection (x2) Comp. Fitting	mm	20	@ 551 kPa	Celsius	113°
Air Cleaners	Dry Paper Type		@ 689 kPa	Celsius	122°
Bore Lubrication	P.T.F.E / Graphite		@ 850 kPa	Celsius	147°
Oil Capacity of Crankcase	N/A		Maximum Lubricant Consumed		
Type of Drive	V-belt	2A	in 100 hours Operation	N/A	
Approximate Net Weight	kgs	52	Noise Level at 1 metre	dB(A)	82
Rotation Looking at Flywheel	Anti-clockwise				

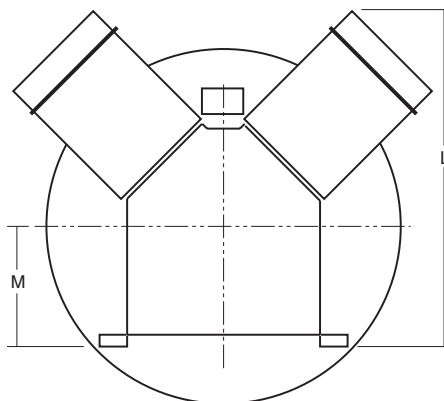
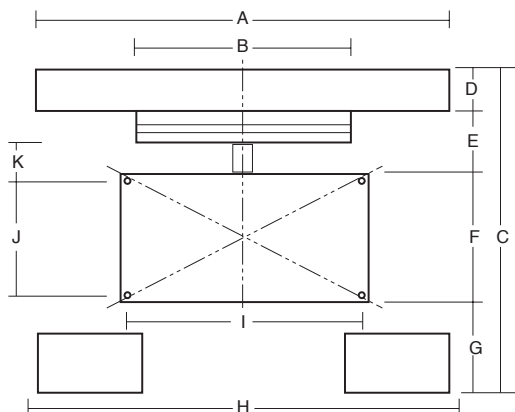

A	500 mm
B	250 mm
C	440 mm
D	60 mm
E	95 mm
F	185 mm
G	100 mm
H	570 mm
I	258 mm
J	135 mm
K	80 mm
L	415 mm
M	130 mm

Forbes (Aust) Pty Ltd reserves the right to change the specifications of any of its products without prior notice