

SWAN model SD-205 Single stage OIL FREE 2 cyl. air cooled

Rev. No. CS0412-SD205

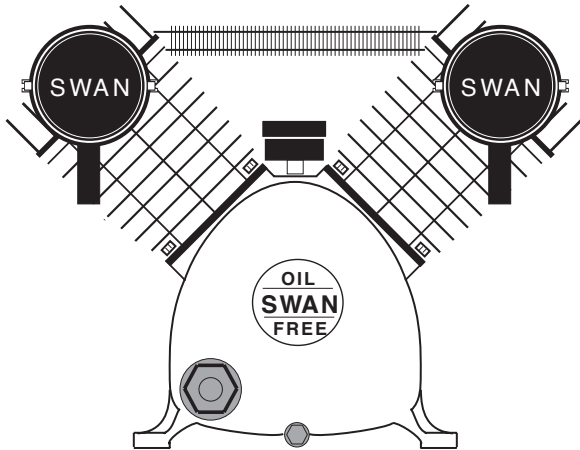

SD-205 PERFORMANCE

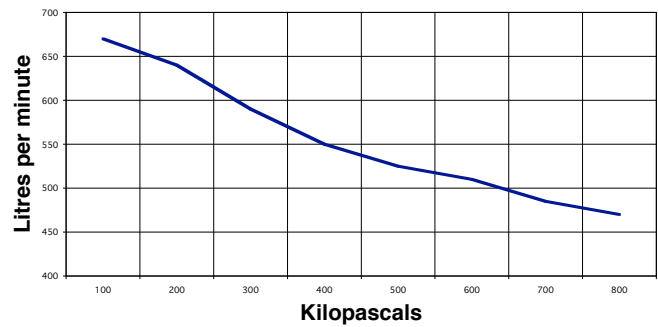

Main Construction Material	Cast Iron / Alloy	<i>The following are at normal speed with an ambient temperature of 31.1°C & inlet air of 101 kPa g pressure.</i>			
Bore	mm	95	Piston Displacement	L/min	694
Stroke	mm	70	Free Air Delivery @ 689 kPa	L/min	485
Minimum Speed	rpm	200	Shaft Input:		
Normal Speed	rpm	700	@ 415 kPa	kW	2.85
Maximum Speed	rpm	700	@ 551 kPa	kW	2.97
Minimum Working Pressure	kPa	275	@ 689 kPa	kW	3.21
Maximum Working Pressure	kPa	850	@ 860 kPa	kW	3.33
Minimum Ambient Temperature	Celsius	0°	Temperature of Air Discharge:		
Maximum Ambient Temperature	Celsius	45°	@ 415 kPa	Celsius	125°
Air Connection (x2) Comp. Fitting	mm	25	@ 551 kPa	Celsius	140°
Air Cleaners	Dry Paper Type		@ 689 kPa	Celsius	150°
Bore Lubrication	P.T.F.E / Graphite		@ 860 kPa	Celsius	173°
Oil Capacity of Crankcase	N/A		Maximum Lubricant Consumed		
Type of Drive	V-belt	2SPZ	in 100 hours Operation	N/A	
Approximate Net Weight	kgs	71	Noise Level at 1 metre	dB(A)	83
Rotation Looking at Flywheel	Anti-clockwise				

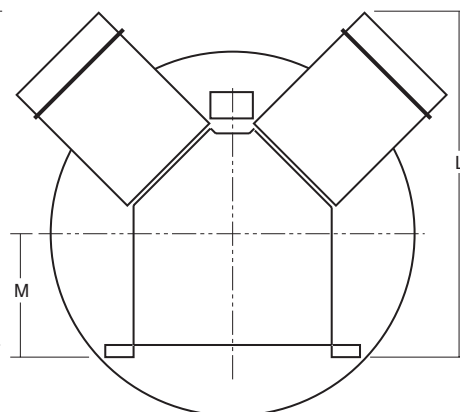
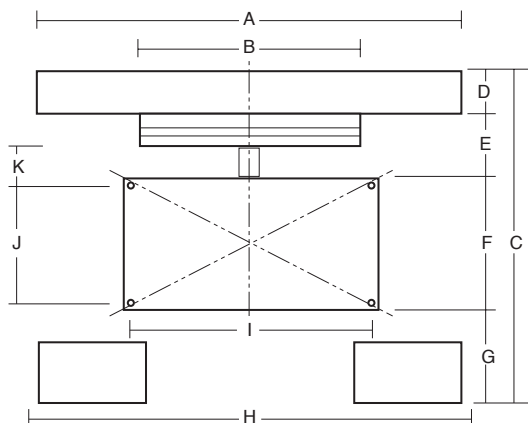

A	560 mm
B	250 mm
C	460 mm
D	60 mm
E	114 mm
F	180 mm
G	120 mm
H	625 mm
I	275 mm
J	130 mm
K	90 mm
L	460 mm
M	152 mm

Forbes (Aust) Pty Ltd reserves the right to change the specifications of any of its products without prior notice