

6 HOLES Ø14 ON 260 PCD.

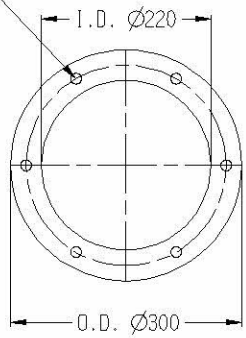

**DETAIL: STACK FLANGE**

NOTE: STRESSES ASSOCIATED WITH EXTERNAL OR ENVIRONMENTAL EFFECTS HAVE NOT BEEN CONSIDERED IN THIS DESIGN. ANY PROJECT SPECIFIC LOADINGS WILL REQUIRE EVALUATION TO ENSURE THAT THEY DO NOT APPLY NEW LOADS NOT ALLOWED FOR IN THIS DESIGN.

THE CONFIGURATION AND DIMENSIONS OF THE BURNER GAS TRAIN CAN VARY DEPENDING ON GAS SUPPLY PRESSURE AND SITE SPECIFICATIONS. HUNT BOILERS CAN PROVIDE GAS TRAIN CONFIGURATION AND DIMENSION ON RECEIPT OF THE DESIGN CRITERIA FOR YOUR PROJECT.

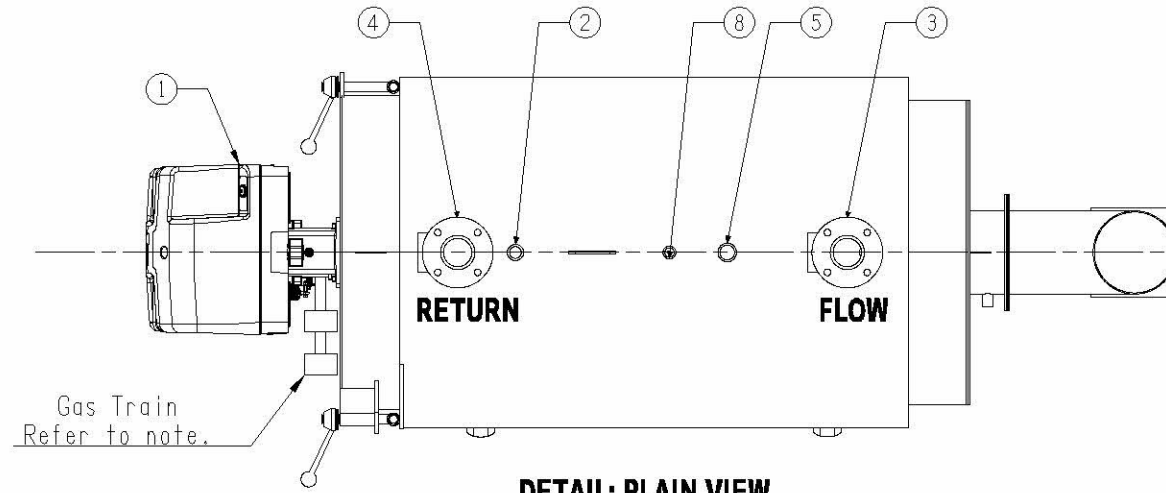

**DETAIL: PLAIN VIEW**

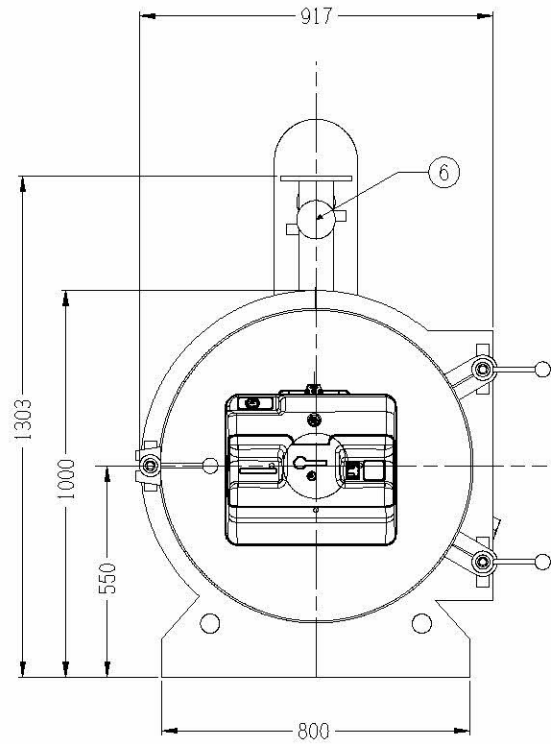

**DETAIL: FRONT ELEVATION**

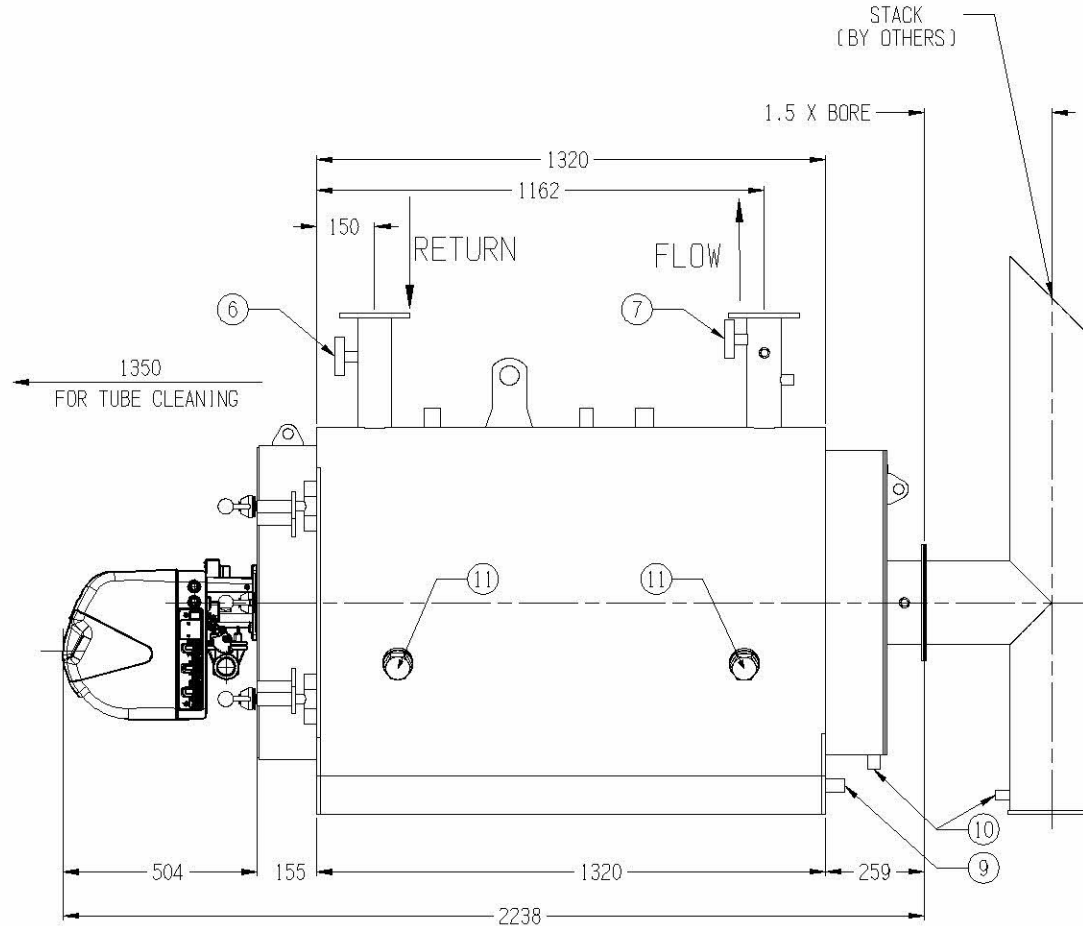

**DETAIL: SIDE ELEVATION**

**IN THE INTEREST OF CONTINUOUS IMPROVEMENT HUNT BOILERS RESERVES THE RIGHT TO CHANGE THE SPECIFICATIONS OF ITS PRODUCTS WITHOUT PRIOR NOTICE.**



**SPECIFICATIONS:**

TNAR SERIES  
HOT WATER HEATER  
MODEL: TNAR300 (300KW)  
DESIGN REFERENCE: AS1210-2010  
CLASS: 3

DEIGNATION NUMBER: AS1210-3  
OUTPUT CAPACITY: 300 kW  
MAX. OPERATING TEMPERATURE: 99°C  
MAX. OPERATING PRESSURE: 570 kPa  
DESIGN PRESSURE: 600 kPa  
TEST PRESSURE: 936 kPa  
INPUT: \* 1301 MEGAJOULES/hr  
OUTPUT: 1041 MEGAJOULES/hr  
WATER CONTENT: 340 LITRES  
DRY WEIGHT: 905 kg

HAZARD LEVEL TO AS4343-2005	
OPEN VENTED	"E"
>65°C <90°C	"E"
≥90°C <100°C	"C"

WATER FLOW RATE Kg/sec	ΔT10°C	
	7.32	4.90
WATER PRESSURE DROP kPa	ΔT15°C	
	4.89	2.70
	ΔT20°C	
	3.67	1.37

\* = BASED ON 65°C WATER INLET TO 80°C WATER OUTLET

ITEM	DESCRIPTION	TYPE	STYLE	SIZE	QTY.
12					
11	INSPECTION OPENINGS	SOCKET	BSP	50NB	2
10	CONDENSATE DRAIN CONNECTION	STUB	BSP	20NB	1
9	DRAIN CONNECTION	STUB	BSP	20NB	1
8	LOW LEVEL PROBE CON.	STUB	BSP	32NB	1
7	TEMPERATURE GAUGE	BIMETAL	0-150°C		1
6	PRESSURE GAUGE	BOURDON	0-1000°C		1
5	VENT CONNECTION	STUB	BSP	40NB	1
4	RETURN CONNECTION	FLANGE	TABLE 'E'	80NB	1
3	FLOW CONNECTION	FLANGE	TABLE 'E'	80NB	1
2	SAFETY VALVE	BRONZE	FULL LIFT	25NB	1
1	BURNER	FORCED DRAFT	GUN		1

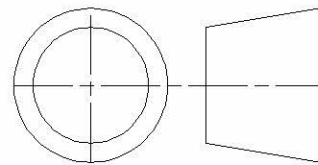

THIRD ANGLE PROJECTION

**HUNT BOILERS**  
A Division of Forbes (Aust) Pty Ltd

THIS DRAWING WAS PREPARED BY HUNT BOILERS. THE INFORMATION IT CONTAINS IS CONFIDENTIAL AND MUST NOT BE USED, DISCLOSED OR REPRODUCED WITHOUT WRITTEN AUTHORITY.

ALL DIMENSIONS IN MILLIMETERS	DRAWN: D.L.D	DESCRIPTION: TNAR300 (300KW) HOT WATER HEATER GENERAL ARRANGEMENT DESIGN REG. #SD20050229-1
DO NOT SCALE THIS DRAWING	DATE: 15/02/08	DRAWING No: TNAR300-GA-01
COMPUTER AIDED DRAFT	CHECKED: DA	

REV	REVISION NOTE	DATE	CKD
C	Burner and specifications updated	10/02/12	DA
B	REVISION B	22/08/08	SC
A	ORIGINAL ISSUE	15/02/08	SC